

Features:

- Slimline Constant Voltage Driver, Flicker free
- AC input: 200-240VAC
- Built in active PFC Function
- Efficiency up to 79%
- Dimming range: 0-100%, Load: 10-100%
- Protections: short circuit/ over loading/ over temperature
- PWM Output, does not change the colour index
- Cooling by free air convection
- Suitable for profile lighting and lightboxes



Models

ELED-30-12T-SL

ELED-30-24T-SL

Output Specifications

	ELED-30-12T-SL	ELED-30-24T-SL
Output Voltage	12V	24V
Voltage Tolerance	<500mV	
Output Current	2.5A	1.25A
Rated Power	30W	

Input Specifications

Input Voltage	200-240VAC
Frequency Range	47-63Hz
Inrush Current	34A, 50%, 104us@230VAC
Full Load Efficiency (Typ.)	79%
AC Current (Max.)	0.20A
Power Factor	PF >0.96/230VAC (Full Loading)

Protection

Short Circuit	Shut down o/p voltage, re-power onto recover after fault condition is removed
Over Loading	<120%, constant current limiting, re-power onto recover
Over Temperature	100°C ±10°C, re-power onto recover
Protection Class	II

Environment

Working Temperature	-40~+60°C (Refer to derating curve)
Working Humidity	20-95% RH, non condensing
Storage Temperature, Humidity	-40~+80°C, 10-95% RH
Temperature Coefficient	±0.03%/°C (0-50°C)

Environment

Vibration 10~500Hz, 2G 10min./1 cycle, period for 60min. each along X,Y,Z axes

Safety & EMC

Safety standards	EN613471, EN61347-2-13, EN62493
Withstand Voltage	I/P-O/P:3.75KVAC I/P-FG:1.88KVAC O/P-FG:0.5KVAC
Isolation Resistance	I/P-O/P I/P-FG O/P-FG: 100MΩ/500VDC/25°C/70%RH
EMC Emission	EN55015, EN61000-3-2, EN61000-3-3
EMC Immunity	EN61000-4-2,3,4,5,6,11, EN61547

Other Specifications

IP Rating	IP20
Weight	0.20 Kg
Size	260 x 30 x 18.5 mm
Packing	330 x 275 x 130 mm (50PCS/CTN)

Mechanical Specifications

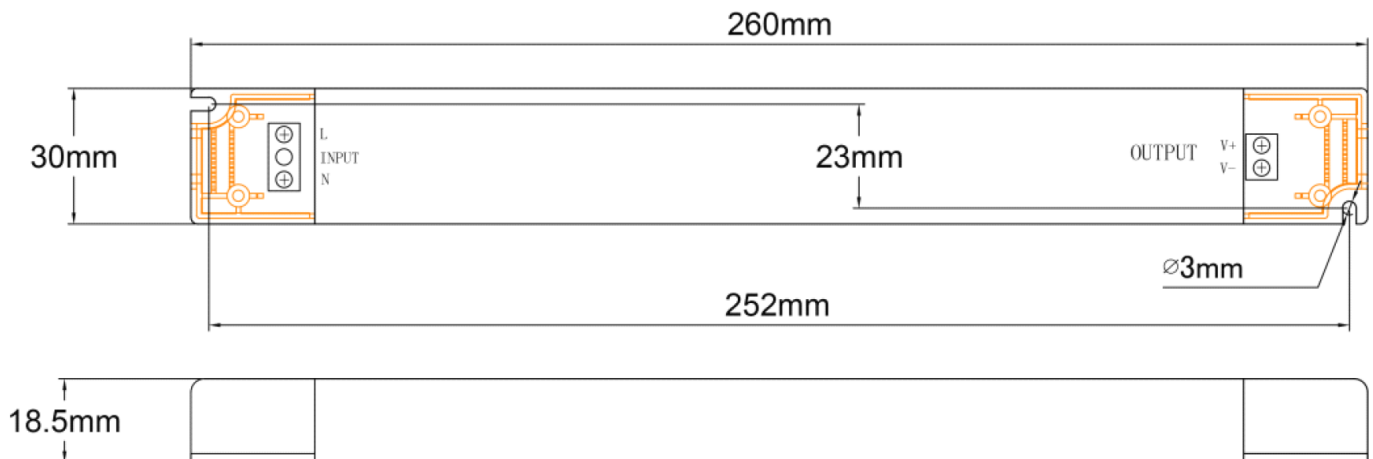

Derating Curve

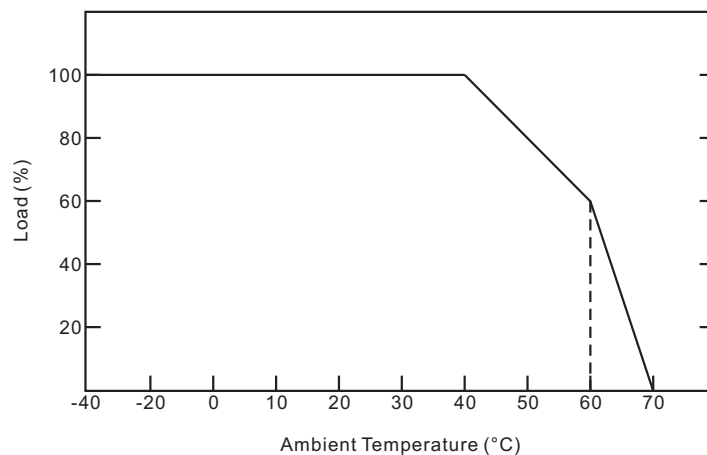

Connecting Diagram

